



© Copyright 2008. Black Box Corporation. All rights reserved.

1000 Park Drive • Lawrence, PA 15055-1018 • 724-746-5500 • Fax 724-746-0746



ServTray

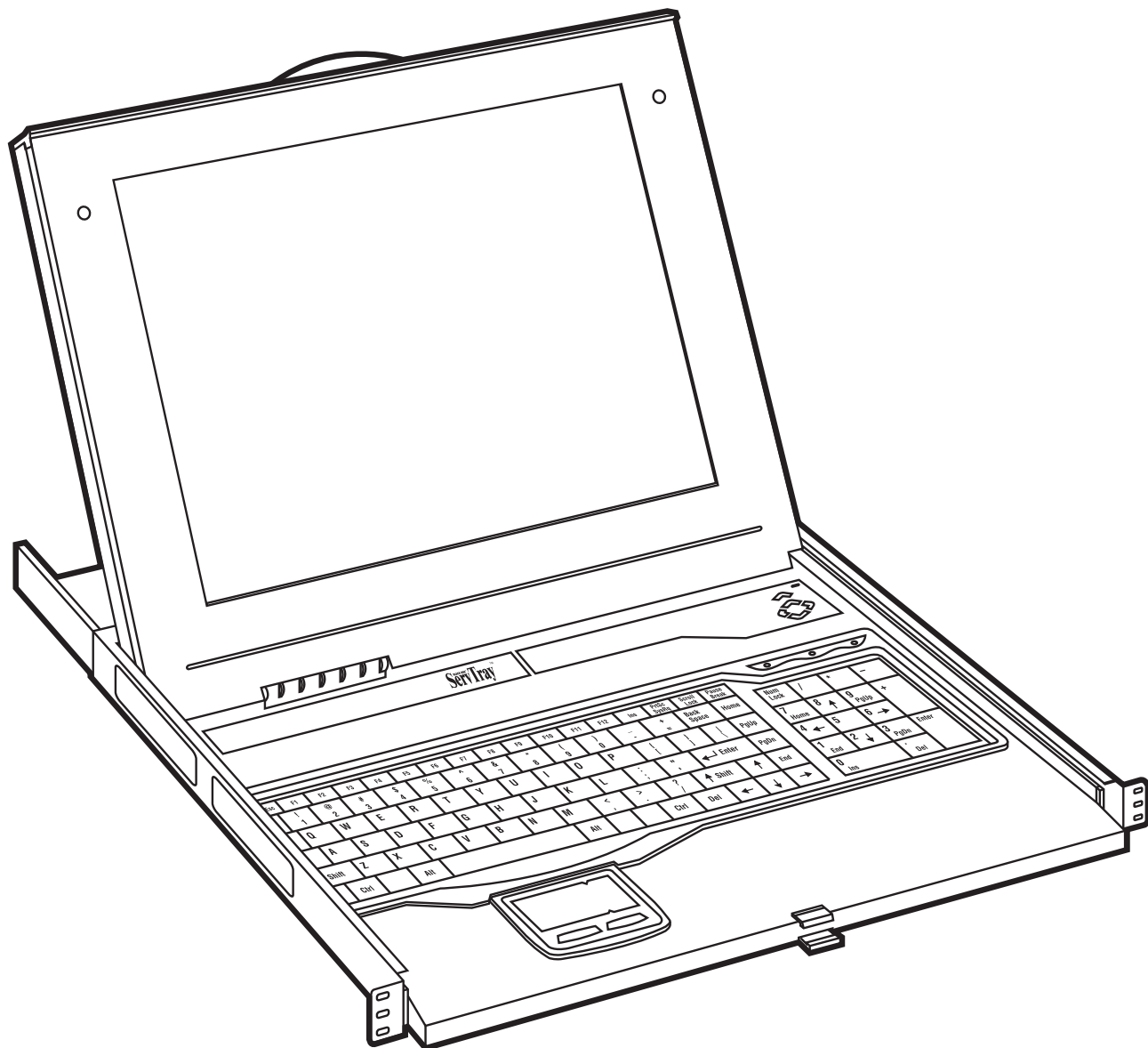

**CUSTOMER
SUPPORT
INFORMATION**

Order **toll-free** in the U.S.: Call **877-877-BBOX** (outside U.S. call **724-746-5500**)
FREE technical support 24 hours a day, 7 days a week: Call **724-746-5500** or fax **724-746-0746**
Mailing address: **Black Box Corporation**, 1000 Park Drive, Lawrence, PA 15055-1018
Web site: www.blackbox.com • E-mail: info@blackbox.com

**FEDERAL COMMUNICATIONS COMMISSION
and INDUSTRY CANADA
RADIO FREQUENCY INTERFERENCE STATEMENTS**

Class B Digital Device. This equipment has been tested and found to comply with the limits for a Class B computing device pursuant to Part 15 of the FCC Rules. These limits are designed to provide reasonable protection against harmful interference in a residential installation. However, there is no guarantee that interference will not occur in a particular installation. This equipment generates, uses, and can radiate radio frequency energy, and, if not installed and used in accordance with the instructions, may cause harmful interference to radio communications. If this equipment does cause harmful interference to radio or telephone reception, which can be determined by turning the equipment off and on, the user is encouraged to try to correct the interference by one of the following measures:

- Reorient or relocate the receiving antenna.
- Increase the separation between the equipment and receiver.
- Connect the equipment into an outlet on a circuit different from that to which the receiver is connected.
- Consult an experienced radio/TV technician for help.

CAUTION

Changes or modifications not expressly approved by the party responsible for compliance could void the user's authority to operate the equipment.

To meet FCC requirements, shielded cables and power cords are required to connect this device to a personal computer or other Class B certified device.

This digital apparatus does not exceed the Class B limits for radio noise emission from digital apparatus set out in the Radio Interference Regulation of Industry Canada.

Le présent appareil numérique n'émet pas de bruits radioélectriques dépassant les limites applicables aux appareils numériques de classe B prescrites dans le Règlement sur le brouillage radioélectrique publié par Industrie Canada.

INSTRUCCIONES DE SEGURIDAD (Normas Oficiales Mexicanas Electrical Safety Statement)

1. Todas las instrucciones de seguridad y operación deberán ser leídas antes de que el aparato eléctrico sea operado.
2. Las instrucciones de seguridad y operación deberán ser guardadas para referencia futura.
3. Todas las advertencias en el aparato eléctrico y en sus instrucciones de operación deben ser respetadas.
4. Todas las instrucciones de operación y uso deben ser seguidas.
5. El aparato eléctrico no deberá ser usado cerca del agua—por ejemplo, cerca de la tina de baño, lavabo, sótano mojado o cerca de una alberca, etc..
6. El aparato eléctrico debe ser usado únicamente con carritos o pedestales que sean recomendados por el fabricante.
7. El aparato eléctrico debe ser montado a la pared o al techo sólo como sea recomendado por el fabricante.
8. Servicio—El usuario no debe intentar dar servicio al equipo eléctrico más allá a lo descrito en las instrucciones de operación. Todo otro servicio deberá ser referido a personal de servicio calificado.
9. El aparato eléctrico debe ser situado de tal manera que su posición no interfiera su uso. La colocación del aparato eléctrico sobre una cama, sofá, alfombra o superficie similar puede bloquea la ventilación, no se debe colocar en libreros o gabinetes que impidan el flujo de aire por los orificios de ventilación.
10. El equipo eléctrico deber ser situado fuera del alcance de fuentes de calor como radiadores, registros de calor, estufas u otros aparatos (incluyendo amplificadores) que producen calor.
11. El aparato eléctrico deberá ser conectado a una fuente de poder sólo del tipo descrito en el instructivo de operación, o como se indique en el aparato.
12. Precaución debe ser tomada de tal manera que la tierra física y la polarización del equipo no sea eliminada.
13. Los cables de la fuente de poder deben ser guiados de tal manera que no sean pisados ni pellizcados por objetos colocados sobre o contra ellos, poniendo particular atención a los contactos y receptáculos donde salen del aparato.
14. El equipo eléctrico debe ser limpiado únicamente de acuerdo a las recomendaciones del fabricante.
15. En caso de existir, una antena externa deberá ser localizada lejos de las líneas de energía.
16. El cable de corriente deberá ser desconectado del cuando el equipo no sea usado por un largo periodo de tiempo.
17. Cuidado debe ser tomado de tal manera que objetos líquidos no sean derramados sobre la cubierta u orificios de ventilación.
18. Servicio por personal calificado deberá ser provisto cuando:
 - A: El cable de poder o el contacto ha sido dañado; u
 - B: Objetos han caído o líquido ha sido derramado dentro del aparato; o
 - C: El aparato ha sido expuesto a la lluvia; o
 - D: El aparato parece no operar normalmente o muestra un cambio en su desempeño; o
 - E: El aparato ha sido tirado o su cubierta ha sido dañada.

TRADEMARKS USED IN THIS MANUAL

BLACK BOX and the Double Diamond logo are registered trademarks, and ServTray and ServSwitch are trademarks, of BB Technologies, Inc.

Centronics is a registered trademark of Centronics Corporation.

PS/2 is a registered trademark of International Business Machines Corporation.

UL is a registered trademark of Underwriters Laboratories Inc.

Any other trademarks mentioned in this manual are acknowledged to be the property of the trademark owners.

Contents

Chapter	Page
1. Specifications	5
2. Overview	7
2.1 Introduction	7
2.2 What's Included	8
3. Installation	10
4. Operation	15
5. Troubleshooting	16
5.1 Calling Black Box	16
5.2 Shipping and Packaging	16

1. Specifications

Active Display Area: KVT415A: 9"H x 12"W (22.8 x 30.4 cm);
KVT417A: 10.6"H x 13.3"W (27 x 33.8 cm);
KVT419A: 11.8"H x 14.8"W (30.1 x 37.6 cm)

Approvals: CE, FCC for the product; UL[®], TUV, CE for power supply

Backlight Unit: KVT415A: 2 CCFLs edge-light (top/bottom);
KVT417A, KVT419A: 4 CCFLs edge-light (top/bottom)

Brightness (cd/m²): 250 (center)

Contrast Ratio (typical): KVT415A: 350:1;
KVT417A: 450:1;
KVT419A: 500:1

Display Color (RGB 6-bits data): KVT415A, KVT417A: 262 K colors;
KVT419A: 16.7 M colors

Display Mode: Normally white

Input Signal: RGB analog, H/V separate

Pixel Pitch: KVT415A: 0.297 mm (H) x 0.297 mm (V);
KVT417A: 0.264 mm (H) x 0.264 mm (V);
KVT419A: 0.294 mm (H) x 0.294 mm (V)

Plug-n-Play VESA: VESA DDC 1/2B

Resolution: KVT415A: 1024 x 768 @ 60 Hz;
KVT417A, KVT419A: 1280 x 1024 @ 60 Hz

NOTE

For optimum video performance, VGA resolution should be set to 1024 x 768 (for the KVT415A) or 1280 x 1024 (for the KVT417A or KVT419A).

Viewing Angle (typical): KVT415A: -70 to +70 (H), -60 to +60 (V);
KVT417A: -80 to +80 (H), -80 to +80 (V);
KVT419A: -85 to +85 (H), -85 to +85 (V)

Connectors: (1) Centronics[®] female

Temperature: Operating: 32 to 122°F (0 to 50°C);
Storage: -4 to +140°F (-20 to +60°C)

Humidity (Relative): Operating: 95%;
Storage: 95%

SERVTRAY

Power Consumption (maximum, typical): KVT415A: 33 watts;
KVT417A: 37 watts;
KVT419A: 40 watts

Power: 12 VDC (from external 100–240-VAC power adapter), 47–63 Hz

Size: KVT415A: 1.75"H (1U) x 15"W x 19.5" to 39.5"D (4.4 x 38.1 x 49.5 to 100.3 cm);
KVT417A: 1.75"H (1U) x 17"W x 19.5" to 39.5"D (4.4 x 43.2 x 49.5 to 100.3 cm);
KVT419A: 1.75"H (1U) x 19"W x 19.5" to 39.5"D (4.4 x 48.3 x 49.5 to 100.3 cm)

Weight: KVT415A: 21 lb. (9.5 kg);
KVT417A: 23 lb. (10.4 kg);
KVT419A: 25 lb. (11.3 kg)

2. Overview

2.1 Introduction

Each ServTray Kit includes a ServTray™ (KVT415A, KVT417A, or KVT419A), a KVM module (KVT4S1UV, KVT4S8PV, KVT4S8UV, KVT4S16PV, or KVT4S16UV), and a Rear Bracket Extension Kit (RMB1, RMB2, RMB3, RMB4, or RMB5). This manual describes how to use the ServTray and the Rear Bracket Extension Kit, and a separate manual (included with your kit) explains how to use the KVM module.

Control your 4-post-rack- or cabinet-mounted USB or PS/2® server with the compact, easy-to-use ServTray. It consists of a keyboard, mouse, LCD panel, and KVM module housed in an industry-standard 19" 1U-height rack drawer (see Figure 2-1).

Three models are available: the ServTray with a 15" LCD panel (KVT415A), the ServTray with a 17" LCD panel (KVT417A), and the ServTray with a 19" LCD panel (KVT419A). All models feature a full 105-key, low-profile, sturdy keyboard and touch pad with an ergonomically designed hand rest. The KVT415A has a maximum resolution of 1024 x 768, and the KVT417A and KVT419A have a maximum resolution of 1280 x 1024.

Install the ServTray in 4-post racks or cabinets that are 20"D to 39.5"D (50.8 to 100.3 cm). When installing the ServTray, you'll need to use the Rear Bracket Extension Kit (described in **Section 2.2**) that's included in your ServTray Kit.

A KVM module is also included with the ServTray. To control more than one USB or PS/2 server, connect the ServTray to a ServSwitch™.

The KVM module comes with a universal Centronics® 36-pin connector; use it to connect the module to the console drawer. The module has a barrel connector for power. The small screws listed in **Section 2.2** secure the RMB1–RMB5 brackets to the KVM module. The large screws are used in place of 10-32 or 12-24 screws (described in **Chapter 3**, not included) if required by your rack.

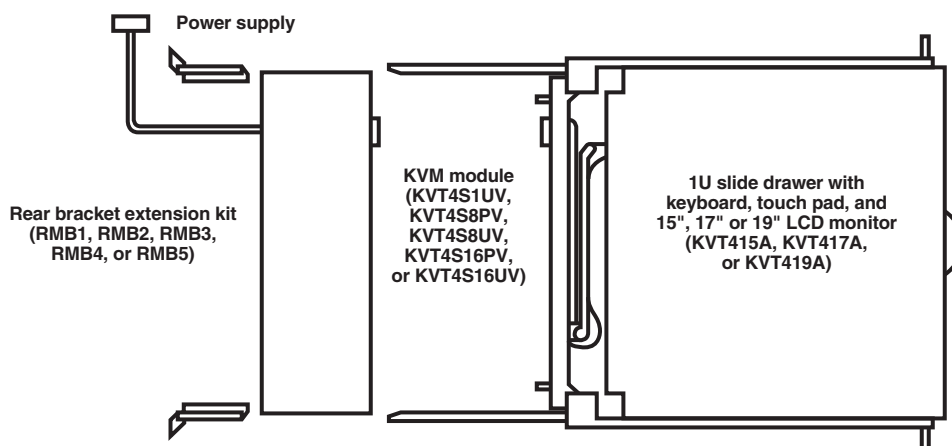

Figure 2-1. ServTray Kit components (left to right): Rear Bracket Extension Kit, KVM Module with power supply, and 1U slide drawer.

2.2 What's Included

- (1) ServTray 15", 17", or 19" LCD console (LCD panel, keyboard, and mouse pad console drawer)
- (1) KVM module with power supply (based on product code)
- (1) rear rail kit (depth based on product code)
- (10) 0.19" x 0.43" (0.5 x 1.1 cm) screws
- (10) 0.12" x 0.24" (0.3 x 0.6 cm) screws
- This user's manual

Accessories that you might or will need to purchase include:

- 12-24 or 10-32 nuts/bolts (you might need these)
- Rear Bracket Extension Kit (RMB1–RMB5): These kits contain two rear brackets, two extensions, and two end rails. Make sure you have the correct kit to fit the depth of your 4-post rack or cabinet (see below).

NOTE

The following length is the depth measured between the front pole and rear pole inside a 4-post rack or cabinet, not the outside depth of the enclosure.

Depth	RMB1		RMB2		RMB3		RMB4		RMB5	
	inch	cm	inch	cm	inch	cm	inch	cm	inch	cm
Minimum	19.5	49.5	22.625	57.5	26.625	67.6	30.5	77.5	34.5	87.6
Maximum	22.375	56.8	27.75	70.5	31.625	80.3	35.625	90.5	39.5	100.3

Figure 2-2 shows the Rear Bracket Extension Kit, and Figure 2-3 shows the ServTray in its maximum and minimum extension positions.

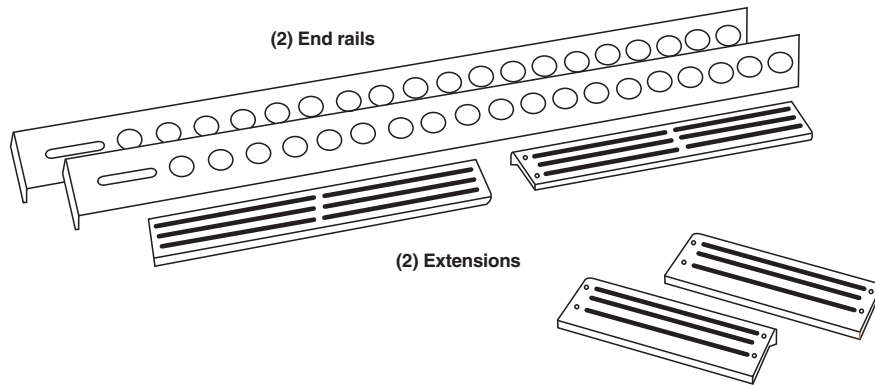

Figure 2-2. Rear Bracket Extension Kit.

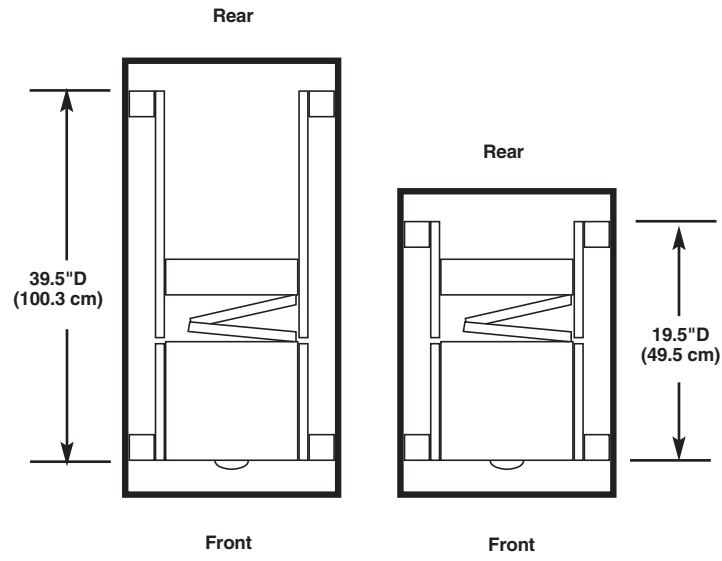

Figure 2-3. ServTray maximum and minimum depths.

3. Installation

1. Choose a proper position in the cabinet for the rack drawer. Using 10-32 or 12-24 hardware (not included), mount the rear brackets (from the Rear Bracket Extension Kit [RMB01–RMB05], included with your ServTray Kit) and lightly fasten them onto the rear vertical poles. (See Figure 3-1.) Both rear brackets will be removed later.

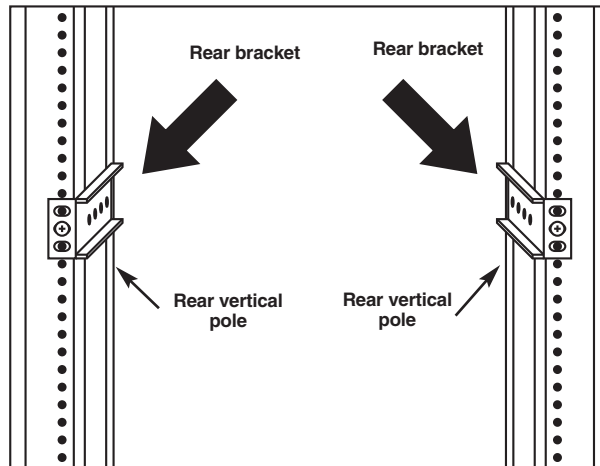

Figure 3-1. Attaching the rear brackets to the cabinet's rear vertical poles.

2. Remove the safety stopper from the console drawer. (See Figure 3-2.) The safety stopper keeps the drawer from sliding out during transportation.

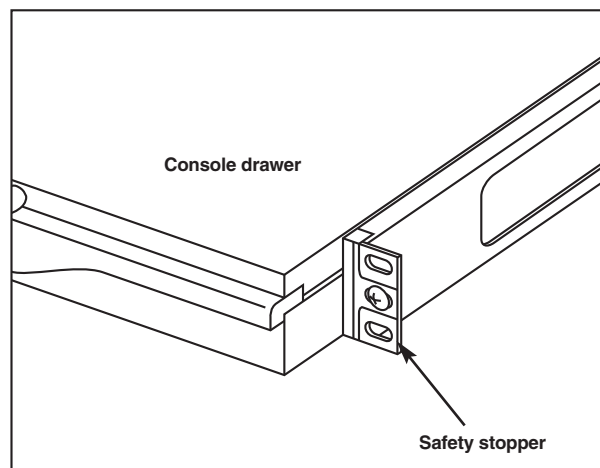

Figure 3-2. Locating and removing the safety stopper.

WARNING

After the safety stopper is removed, the drawer may slide out when tilted. This could cause serious injury; keep the drawer assembly level to avoid this.

- Slide the console drawer into the rack cabinet from the front. Then insert the console drawer's two slide rails into the rear brackets' pockets. See Figure 3-3.

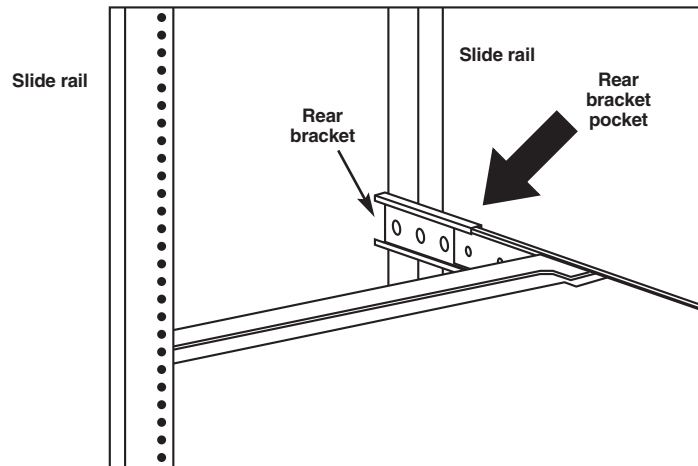

Figure 3-3. Installing the console drawer's two slide rails into the cabinet's brackets.

- Use four 10-32 or 12-24 screws (not included) to fasten the console drawer onto the front brackets. (See Figure 3-4.) The metal brackets shown in the figure support the console's rear side.

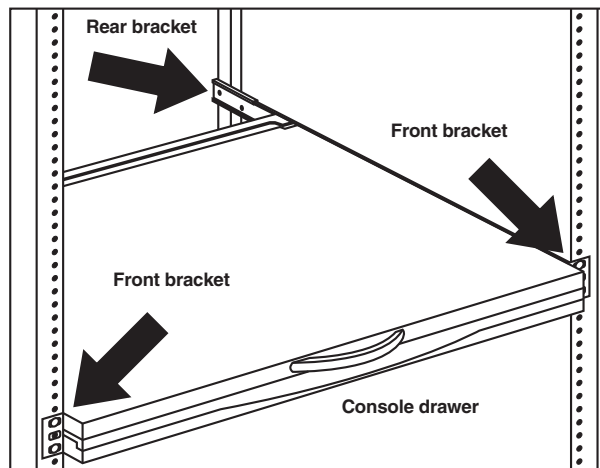

Figure 3-4. Securing the console drawer to the cabinet's front brackets.

- Remove both of the loosely connected rear brackets and slide the console drawer out halfway to balance its weight. (See Figure 3-5.) The front brackets are now supporting the console drawer.

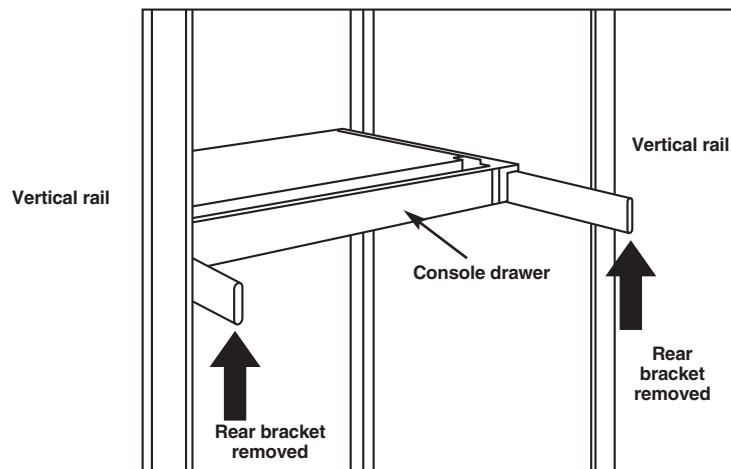

Figure 3-5. Front brackets support the console drawer.

- Using four screws (included), attach the module to the rack. Then slide the extensions (from the Rear Bracket Extension Kit) into both KVM module sides. Attach either the short or long extensions (depending on your kit), as shown in Figure 3-6.

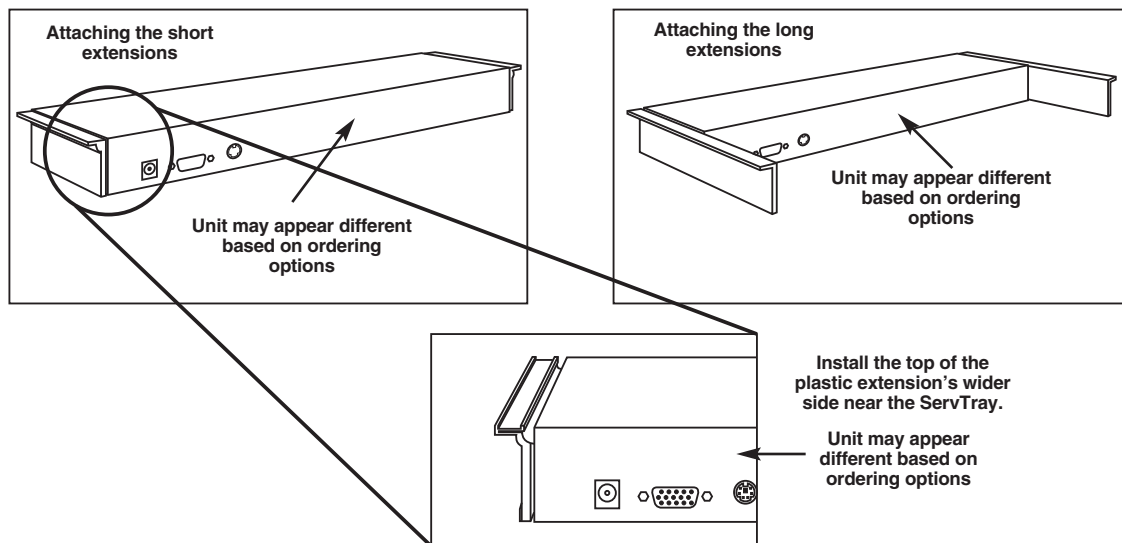

Figure 3-6. Attaching the extensions to the KVM module.

- The rear brackets, extensions, and slide rails fit tightly. Make sure you follow these steps carefully for easy installation.
 - Slide the rear brackets onto the extensions.

- b) Insert the console drawer's two sliding rails into the tight space formed by the rear brackets and the extensions. With both hands, push in the KVM module *evenly* on the right and left sides.
8. Push the rear brackets all the way in and fasten them.
9. Slide out the console drawer. Push the KVM module evenly toward the drawer and secure both units using the attached thumbscrews. See Figure 3-7.

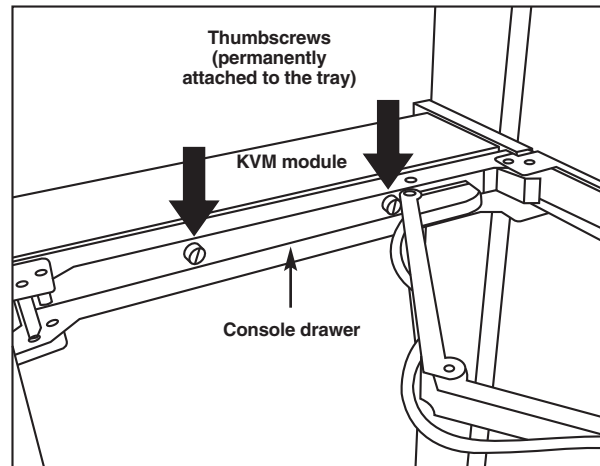

Figure 3-7. Securing the KVM module to the console drawer.

10. Make sure the Centronics connectors on the KVM module and attached cable are firmly mated. See Figure 3-8.

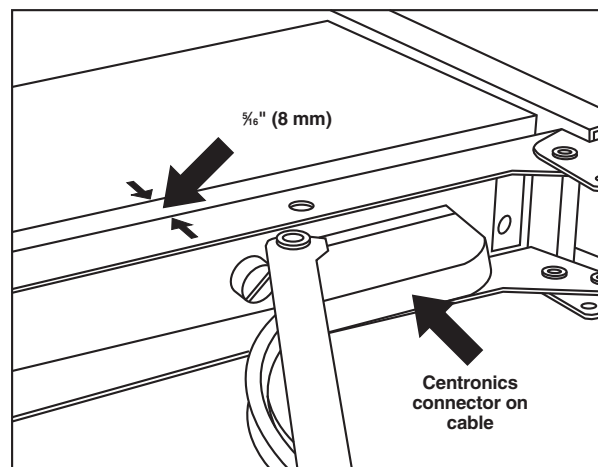

Figure 3-8. Centronics connectors.

11. Connect the power supply to the barrel connector on the KVM module.
12. For operation, pull out the drawer from the 4-post rack or cabinet and latch it in the extended position. A locking mechanism locks the drawer when it's pulled out, pushed in, or folded down. When not in use, push in the drawer, then fold down, lock, and secure the display.

13. Once the ServTray is installed in the 4-post rack or cabinet, you can connect it to a computer. The KVM module's connectors attach to the KVM connectors on a PS/2 CPU via the 3-in-1 (PS/2, PS/2, VGA) Cable (included) or they connect to the HD15 and keyboard/mouse connectors on a USB CPU via the 2-in-1 (USB, VGA) cable (included). Both cables are shown in Figure 3-9.

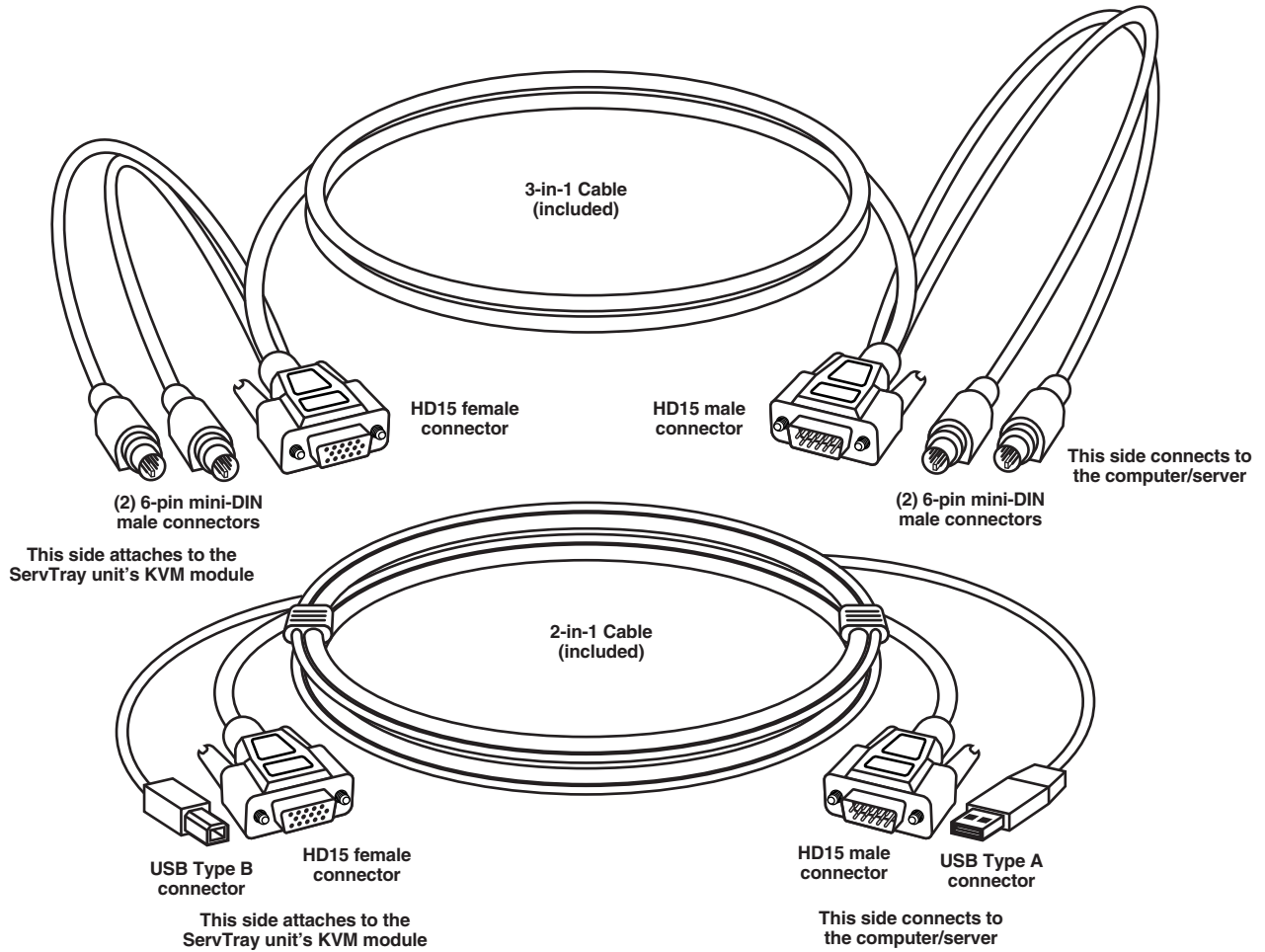

Figure 3-9. Cable for connecting the KVM module to a computer.

NOTE

These cables are included only with the 1-Port VGA PS2/USB (KVT4S1UV) module.

4. Operation

Once the ServTray is installed and connected to a PS/2 or USB CPU or ServSwitch, it's ready for operation. Control the unit via the buttons on the LCD panel (labeled 1 and 2 in Figure 4-1) and the LCD panel power switch (labeled 3 in Figure 4-1). Monitor the status via the keyboard status indicators (labeled 4, 5, and 6 in Figure 4-1).

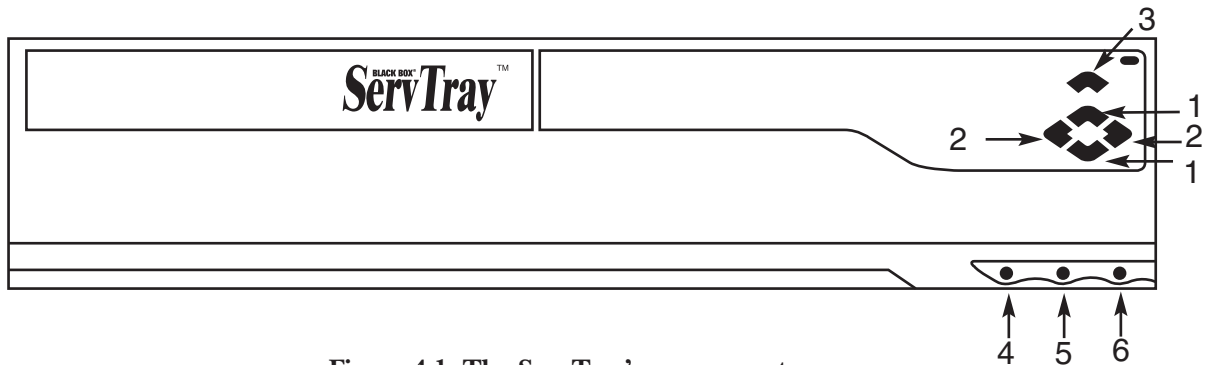

Figure 4-1. The ServTray's components.

1. Use the LCD panel menu buttons (1 in Figure 4-1) to activate the OSD menu to set the LCD panel as an ordinary LCD monitor.
2. Use the LCD panel adjustment buttons (2 in Figure 4-1) to adjust settings for the LCD panel.
3. Switch the power to the LCD panel on or off via the power switch (3 in Figure 4-1).
4. Use the keyboard status indicators (Num Lock, Caps Lock, and Scroll Lock) to view status.
 - The Num Lock Key LED (labeled 4) shows the Keyboard Num Lock status (on or off).
 - The Caps Lock Key LED (labeled 5) shows the Keyboard Caps Lock status (on or off).
 - The Scroll Lock Key LED (labeled 6) shows the Keyboard Scroll Lock status (on or off).
5. Use the touch pad (see Figure 4-2) to simulate a wheel mouse. The touch pad's area to the right side of the two small triangular marks is the simulated scroll area. Move your finger along this area to scroll up or down on the computer's screen. The touch pad area enables you to move the cursor anywhere on your computer's screen by sliding your finger along this area.

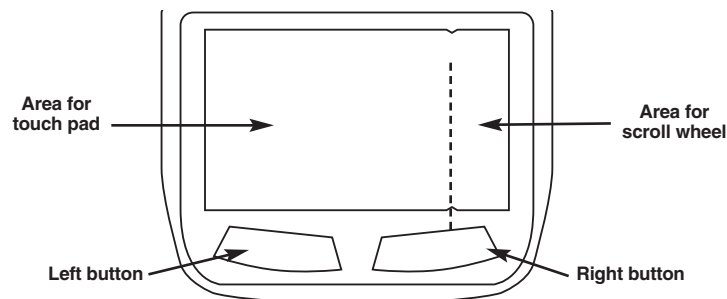

Figure 4-2. Touch pad.

5. Troubleshooting

5.1 Calling Black Box

If you determine that your ServTray is malfunctioning, do not attempt to alter or repair the unit. It contains no user-serviceable parts. Contact Black Box at 724-746-5500.

Before you do, make a record of the history of the problem. We will be able to provide more efficient and accurate assistance if you have a complete description, including:

- the nature and duration of the problem.
- when the problem occurs.
- the components involved in the problem.
- any particular application that, when used, appears to create the problem or make it worse.

5.2 Shipping and Packaging

If you need to transport or ship your ServTray:

- Package it carefully. We recommend that you use the original container.
- If you are shipping the ServTray for repair, make sure you include everything that came in the original package. Before you ship, contact Black Box to get a Return Authorization (RA) number.